

Distributed BY

**JustCatering.Com Ltd**

10 Jessop Avenue, Norwood Green, Middlesex, UB2 5UY, UK

Tel +44 (0)8450034271 Mobile: 07929291670

E-mail: [sales@justcatering.com](mailto:sales@justcatering.com) Web: <http://www.justcatering.com>

---

Ice machines

---

Refrigerators

---

Sushi cases

---

ROX

---

**Export**



**HOSHIZAKI**

# Hoshizaki, the art of ice making!

	Cube ice	Crescent ice	Flake/ nugget ice	Cubelet/ shuttle ice
				
Gastronomy 	IM DIM	KM	FM	DCM CM
Catering 	IM DIM	KM	FM	DCM CM
Convenience store/ supermarkets 			FM	DCM CM
Food processing 		KM	FM	
Gyms/fitnesscentres/saunas 	IM DIM		FM	DSM DCM CM
Healthcare/laboratories 		KM	FM	DSM DCM CM
Other 	IM DIM	KM	FM	DSM DCM CM



---

## Table of contents

---

About Hoshizaki...		2
<b>IM</b>	cube ice machines	3
	self contained	5
	modular	8
<b>KM</b>	crescent ice machines	10
	self contained	11
	modular	12
<b>FM</b>	flake/nugget ice machines	15
	self contained	16
	modular	17
<b>DSM/DCM/DIM</b>	ice and water dispensers	20
<b>B/F</b>	storage bins	23
<b>Transport system</b>	SBF transport system	25
	ITS	25
<b>C</b>	crushers	26
<b>HRE/HFE/RTE/FTE</b>	refrigerators and freezers	27
	uprights	27
	counters	29
<b>HNC</b>	sushi cases	31
<b>ROX</b>		33
<b>Accessories</b>		37

### Operating limits:

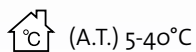

(A.T.) 5-40°C



(W.T.) 5-35°C



0,5-8 bar

- Ice production capacity (kg/24h) at T ambient 10°C, T water 10°C.
- Alternative voltage/cycles on request.



*Prices do not include VAT/other taxes.*

*Prices and specifications are subject to change without prior notice.*



## About Hoshizaki...

Hoshizaki Europe's parent company, Hoshizaki Electric Company, was established in February 1947 in Nagoya, Japan by Mr. Shigetoshi Sakamoto. Over the years, Hoshizaki Electric has manufactured and sold a variety of products including stoves, refrigerators and freezers, vending machines, water purifiers, dispensers and refrigerated display cases. Since the launch of its first ice machine in 1965 Hoshizaki has grown significantly. In 1981, Hoshizaki America was established in Peachtree City, Georgia. Eleven years later Hoshizaki Europe was established in Amsterdam in the Netherlands to expand the business in Europe, Africa and the Middle East.

Today, Hoshizaki Electric Company operates 6 plants in Japan, 2 in the United States, 1 in the United Kingdom and 1 in China. The total Hoshizaki group comprises 46 affiliated companies around the world with 10.000 employees, providing the highest level of quality in the products and services delivered to all customers and resulting in sales of over 1 million icemakers in more than 60 countries worldwide. Building on its long and reputable history, Hoshizaki, through its team of dedicated Research and Development engineers, continues to provide new and innovative products cementing its international reputation for quality and reliability.

Factory in Telford, UK



In 2006 Hoshizaki acquired the American Lancer Corporation, a leading, global manufacturer and marketer of beverage dispensing systems. Halfway through 2008 the Danish Gram Commercial A/S joined the Hoshizaki group focusing on high quality refrigeration for professional use.

Throughout Hoshizaki's eighteen years of operation in Europe, sales offices were established in Belgium, The Netherlands, France, Germany, United Kingdom and Spain. In other European countries, Africa and the Middle East an extensive dealer network has been built up.



---

## Ice machines

---

Hoshizaki is widely considered to be one of the world's leading manufacturers of ice machines and is committed to providing an outstanding level of reliability and performance to ensure customers can depend on them season after season, year after year. The range encompasses many machines that make different types of ice for different users across a wide span of industry sectors. However, all the machines bear the unique hallmark of quality that is associated with Hoshizaki.

The product range include machines for cube ice, cubelet ice, crescent ice, flake ice, nugget ice and ice dispensers with models suitable for small cafés or bars right through to large, modular, industrial models.

All machines are originally designed and specified by a massive Japanese Research & Development team employing over 150 engineers. The basic designs and major component parts are specified for a global market meaning that Hoshizaki machines will effortlessly and quickly achieve outstanding levels of efficiency in ambient temperatures of between 5°C and 40°C even in humid environments.

Parts are precision engineered exclusively for each machine to further enhance the most efficient operation. Bins are polyurethane foam injected for insulation. A closed environment is created by precision made doors with gaskets. This minimises meltage and decreases the number of ice production cycles.

---

### IM, cube ice machines

---

Ice is the finishing touch to any cold drink and the quality of ice can leave a lasting impression with the customer. Hoshizaki IM machines produce exceptionally hard, crystal clear ice cubes. This ice melts very slowly, allowing customers to enjoy their cooled drinks longer. Five different sizes of ice cubes are available.

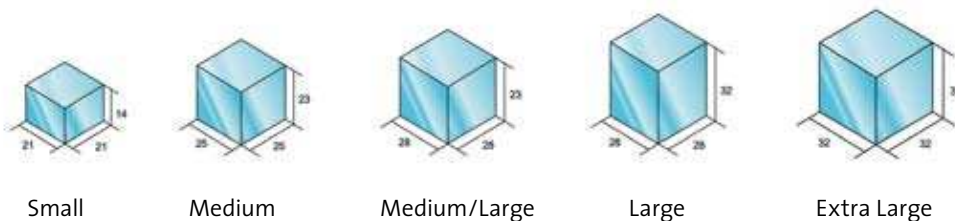

Small (21):	21 x 21 x 14 mm
Medium (25):	25 x 25 x 23 mm
Medium/Large (23):	28 x 28 x 23 mm
Large (standard):	28 x 28 x 32 mm
Extra Large: (IM240DME32)	32 x 32 x 32 mm



## IM, cube ice machines

### Unique production system

The unique IM range of ice makers is designed with hygiene as a priority and utilises a closed cell ice making system that has an automatic rinse and flush cycle. This means that, after every new batch of ice, the water reservoir will drain, rinse and then refill with fresh water.

1. With the water plate closed against the underside of the evaporator, the water circuit is closed to both outside contamination and water loss under normal circumstances. Importantly, each cube is made individually by a dedicated jet spray to ensure the highest possible ice quality.
2. As the ice cube slowly forms, the spray continues till the end of the cycle. No fresh water is required as the internal reservoir capacity is adequate for a full cycle of ice.
3. When the cube is fully formed, the electronic controller initiates a hot gas defrost cycle. The water plate opens and the hot gas slowly warms the evaporator. At this point, all remaining water from the ice making cycle is drained.
4. Eventually, the ice will drop from the evaporator into the ice bin. The water plate will be rinsed with fresh water to remove any remaining particles before it starts to close again. Fresh water continues to enter until the reservoir is full to enable a new freeze cycle to commence.

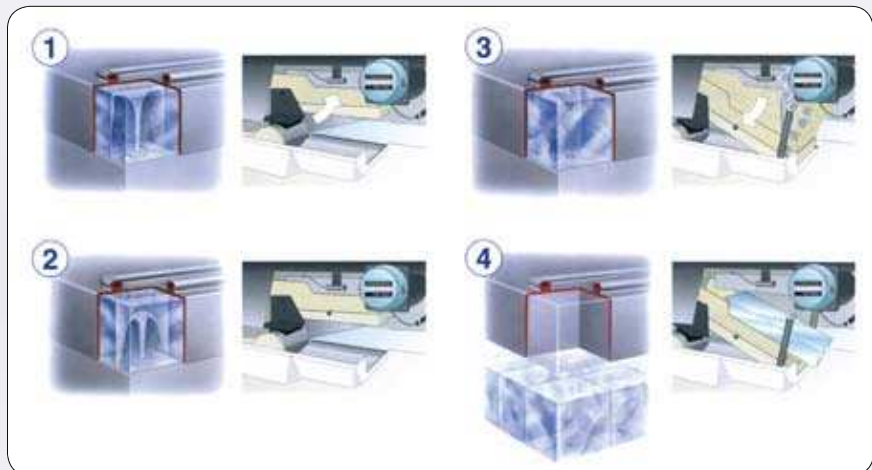

The easy to clean storage bin has high density foam injected insulation to slow down the ice melting, while a gasket on the insulated door ensures the tightest possible fit to prevent particles entering the storage bin that could contaminate the ice. Another valuable feature is the detachable, condenser air filter that can be easily removed for cleaning. A dirt-free air filter helps keep the icemaker performing at maximum yield as per the original design specification.

- Each ice cycle is made with fresh water.
- The water plate is rinsed on every cycle.
- Closed water circuit for ultimate contamination protection.
- Stainless steel exterior.
- Integrated door handles.
- Removable door gaskets.
- Easily cleanable air filter.
- Foam injected polyurethane for outstanding insulation (HFC free).
- Ice machines are micro computer controlled.

The ice production of the IM range varies from 22 – 720 kg in 24 hours. Even in high ambient temperatures, Hoshizaki IM machines are durable and reliable making them suitable across all sizes of bars, pubs, restaurants, cafes, sandwich shops, hotels etc.





## IM, cube ice machines

Self contained

### IM21CLE



Production capacity (kg/24h)	22
Storage bin capacity (kg)	11,5
Dimensions W x D x H (mm)	398 x 495 x 695 <sup>1</sup>
Electrical supply	1/220-240V/50Hz
Electrical consumption (kW)	0,24
Refrigerant	R 134A
Weight (kg)	34

**IM21CLE** (air cooled, L cube)

### IM30CLE



Production capacity (kg/24h)	28
Storage bin capacity (kg)	11,5
Dimensions CLE W x D x H (mm)	398 x 495 x 695 <sup>2</sup>
Dimensions WLE W x D x H (mm)	398 x 448 x 770 <sup>2</sup>
Electrical supply	1/220-240V/50Hz
Electrical consumption (kW)	0,27
Refrigerant	R 134A
Weight (kg)	35

**IM30CLE** (air cooled, L cube)  
**IM30CLE25** (air cooled, M cube)  
**IM30WLE** (water cooled, L cube)  
**IM30WLE25** (water cooled, M cube)<sup>3</sup>

### IM45CLE



Production capacity (kg/24h)	44
Storage bin capacity (kg)	15
Dimensions W x D x H (mm)	633 x 506 x 690 <sup>2</sup>
Electrical supply	1/220-240V/50Hz
Electrical consumption (kW)	0,32
Refrigerant	R 134A
Weight (kg)	54

**IM45CLE** (air cooled, L cube)  
**IM45CLE25** (air cooled, M cube)

<sup>1</sup> Optional: legs for IM21CLE are available upon request.

<sup>2</sup> Legs supplied with IM30 up to IM65 add 100 mm to total height (adjustable to max 135 mm).

<sup>3</sup> Upon request.



## IM, cube ice machines

Self contained

### IM45LE



Production capacity (kg/24h)	44
Storage bin capacity (kg)	18
Dimensions W x D x H (mm)	503 x 456 x 850 <sup>1</sup>
Electrical supply	1/220-240V/50Hz
Electrical consumption (kW)	0,33
Refrigerant	R 134A
Weight (kg)	54

<b>IM45LE</b>	<b>(air cooled, L cube)</b>
<b>IM45LE25</b>	<b>(air cooled, M cube)</b>
<b>IM45WLE</b>	<b>(water cooled, L cube)</b>
<b>IM45WLE25</b>	<b>(water cooled, M cube)<sup>2</sup></b>

### IM65LE



Production capacity (kg/24h)	63
Storage bin capacity (kg)	26
Dimensions W x D x H (mm)	633 x 506 x 850 <sup>1</sup>
Electrical supply	1/220-240V/50Hz
Electrical consumption (kW)	0,4
Refrigerant	R 134A
Weight (kg)	63

<b>IM65LE</b>	<b>(air cooled, L cube)</b>
<b>IM65LE25</b>	<b>(air cooled, M cube)</b>
<b>IM65WLE</b>	<b>(water cooled, L cube)</b>
<b>IM65WLE25</b>	<b>(water cooled, M cube)<sup>2</sup></b>

### IM100LE



Production capacity (kg/24h)	95
Storage bin capacity (kg)	50
Dimensions W x D x H (mm)	704 x 506 x 1200 <sup>3</sup>
Electrical supply	1/220-240V/50Hz
Electrical consumption (kW)	0,63
Refrigerant	R 134A
Weight (kg)	80

<b>IM100LE</b>	<b>(air cooled, L cube)</b>
<b>IM100LE23</b>	<b>(air cooled, ML cube)</b>
<b>IM100LE21</b>	<b>(air cooled, S cube)<sup>2</sup></b>
<b>IM100WLE</b>	<b>(water cooled, L cube)</b>
<b>IM100WLE23</b>	<b>(water cooled, ML cube)<sup>2</sup></b>
<b>IM100WLE21</b>	<b>(water cooled, S cube)<sup>2</sup></b>

<sup>1</sup> Legs supplied with IM30 up to IM65 add 100 mm to total height (adjustable to max 135 mm).

<sup>2</sup> Upon request.

<sup>3</sup> Legs supplied with IM100 up to IM240M2E add 90 mm to total height (adjustable to max 135 mm).







## IM, cube ice machines

Self contained

### IM100CLE



Production capacity (kg/24h)	95
Storage bin capacity (kg)	38
Dimensions W x D x H (mm)	1000 x 600 x 700 <sup>1</sup>
Electrical supply	1/220-240V/50Hz
Electrical consumption (kW)	0,63
Refrigerant	R 134A
Weight (kg)	77

- IM100CLE** (air cooled, L cube)
- IM100CLE23** (air cooled, ML cube)
- IM100CLE21** (air cooled, S cube)<sup>2</sup>

### IM130ME



Production capacity (kg/24h)	130
Storage bin capacity (kg)	50
Dimensions W x D x H (mm)	704 x 506 x 1200 <sup>1</sup>
Electrical supply	1/220-240V/50Hz
Electrical consumption (kW)	0,7
Refrigerant	R 404A
Weight (kg)	80

- IM130ME** (air cooled, L cube)
- IM130ME23** (air cooled, ML cube)
- IM130ME21** (air cooled, S cube)<sup>2</sup>
- IM130WME** (water cooled, L cube)
- IM130WME23** (water cooled, ML cube)<sup>2</sup>
- IM130WME21** (water cooled, S cube)<sup>2</sup>

### IM240M2E



Production capacity (kg/24h)	240
Storage bin capacity (kg)	110
Dimensions W x D x H (mm)	704 x 685 x 1510 <sup>1</sup>
Electrical supply	1/220-240V/50Hz
Electrical consumption (kW)	1,33
Refrigerant	R 404A
Weight (kg)	114

- IM240M2E** (air cooled, L cube)
- IM240M2E23** (air cooled, ML cube)
- IM240M2E21** (air cooled, S cube)<sup>2</sup>
- IM240WM2E** (water cooled, L cube)
- IM240WM2E23** (water cooled, ML cube)<sup>2</sup>
- IM240WM2E21** (water cooled, S cube)<sup>2</sup>

<sup>1</sup> Legs supplied with IM100 up to IM240M2E add 90 mm to height (adjustable to max 135 mm max).

<sup>2</sup> Upon request.

IM cube



## IM, cube ice machines

Modular

### IM24oDME



Production capacity (kg/24h)	240
Dimensions W x D x H (mm)	1084 x 800 x 500
Electrical supply	1/220-240V/50Hz
Electrical consumption (kW)	1,33
Refrigerant	R 404A
Weight (kg)	91
Corresponding bins	see page 23

<b>IM24oDME</b>	(air cooled, L cube)
<b>IM24oDME23</b>	(air cooled, ML cube)
<b>IM24oDME21</b>	(air cooled, S cube) <sup>1</sup>
<b>IM24oDME32</b>	(air cooled, XL cube) <sup>1</sup>
<b>IM24oDWME</b>	(water cooled, L cube)
<b>IM24oDWME23</b>	(water cooled, ML cube) <sup>1</sup>
<b>IM24oDWME21</b>	(water cooled, S cube) <sup>1</sup>
<b>IM24oDWME32</b>	(water cooled, XL cube) <sup>1</sup>

For remote condensor:

<b>IM24oDSME <sup>1</sup></b>	(air cooled, L cube)
<b>IM24oDSME23</b>	(air cooled, ML cube) <sup>1</sup>
<b>IM24oDSME21</b>	(air cooled, S cube) <sup>1</sup>

#### URC24o: remote condensor

IM24oXME extension machine for 480 kg (DME+XME) or 720 kg (DME+2x XME).  
Specifications and prices, see IM24oDME.

### IM24oAME



Production capacity (kg/24h)	210
Dimensions W x D x H (mm)	560 x 700 x 880
Electrical supply	1/220-240V/50Hz
Electrical consumption (kW)	1,3
Refrigerant	R 404A
Weight (kg)	90
Corresponding bins	see page 23

<b>IM24oAME</b>	(air cooled, L cube)
<b>IM24oAME23</b>	(air cooled, ML cube)
<b>IM24oAME21</b>	(air cooled, S cube) <sup>1</sup>
<b>IM24oAWME</b>	(water cooled, L cube)
<b>IM24oAWME23</b>	(water cooled, ML cube) <sup>1</sup>
<b>IM24oAWME21</b>	(water cooled, S cube) <sup>1</sup>

<sup>1</sup> Upon request.





## Special ice



**IM65LE-Q: Ball ice**  
Ø 45 mm - 45 grams



**IM240DNE: Cylinder shaped ice**  
W Ø37\* H43 mm - 42 grams



**IM65LE-S: Star shaped ice**



**IM65LE-H: Heart shaped ice**



**LM-350AE: Big cube**  
48 x 48 x 58 (mm)



**LM-350AE-103: Long cube**  
103 x 48 x 58 (mm)

These are special types of ice and the machines can only be ordered on special request. Therefore take into account a longer delivery time.

special ice



## KM, crescent ice machines

Hoshizaki's KM machines produce clear, crescent shaped ice. Crescent ice is unique in that it moves around freely and packs together tightly in the bin, achieving maximum ice storage capacity. Therefore, there are no air pockets as the individual crescents do not stick together in the storage bin. The unique shape is extremely versatile and extends from the splash-free serving of post mix soft drinks through to diverse applications such as fish transportation and display and even laser therapy.

To produce crescent shaped ice our KM range has a vertical stainless steel evaporator which is exceptionally durable and virtually maintenance free. The cubes produced are crystal clear as only the purest water molecules will freeze on to the evaporator. KM machines not only produce great ice, they are also water and energy efficient. The control board manages the freezing cycles and adjusts the setting to accommodate external factors that influence the ice making process.

The evaporator and the exterior of KM machines are made of stainless steel to ensure hygiene and durability. The access panel is sited conveniently in the front of each unit for easy access.

Its many qualities mean that the KM range is environmentally friendly and has many advantages which make it the ideal choice.

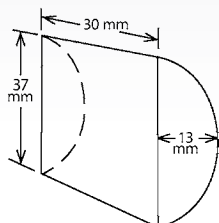

- Easy accessibility for service via front of unit.
- Reduced water and energy consumption.
- Maximum storage capacity.
- Stainless steel evaporator.
- Micro computer control.
- Range includes models producing between 36 and 1168 kgs of ice in 24 hours.





## KM, crescent ice machines

Self contained

**KM35A**



Production capacity (kg/24h)	36
Storage bin capacity (kg)	16
Dimensions W x D x H (mm)	450 x 610 x 840
Electrical supply	1/220-240V/50Hz
Electrical consumption (kW)	0,195
Refrigerant	R 134A
Weight (kg)	39

**KM35A (air cooled)**

Optional:

**Set of 4 legs (+90-135 mm)**

**Drain pump kit**

**KM50A**



Production capacity (kg/24h)	52
Storage bin capacity (kg)	23
Dimensions W x D x H (mm)	603 x 610 x 840
Electrical supply	1/220-240V/50Hz
Electrical consumption (kW)	0,303
Refrigerant	R 134A
Weight (kg)	46

**KM50A (air cooled)**

Optional:

**Set of 4 legs (+90-135 mm)**

**Drain pump kit**

**KM75A**



Production capacity (kg/24h)	72
Storage bin capacity (kg)	40
Dimensions W x D x H (mm)	603 x 712 x 840
Electrical supply	1/220-240V/50Hz
Electrical consumption (kW)	0,412
Refrigerant	R 134A
Weight (kg)	51

**KM75A (air cooled)**

Optional:

**Set of 4 legs (+90-135 mm)**

**Drain pump kit**

KMI crescent





## KM, crescent ice machines

Self contained/modular

**KM100A**



Production capacity (kg/24h)	101
Storage bin capacity (kg)	45
Dimensions W x D x H (mm)	610 x 712 x 840 <sup>1</sup>
Electrical supply	1/220-240V/50Hz
Electrical consumption (kW)	0,584
Refrigerant	R 404A
Weight (kg)	62

**KM100A (air cooled)**

**KM125A**



Production capacity (kg/24h)	125
Storage bin capacity (kg)	55
Dimensions W x D x H (mm)	762 x 712 x 840 <sup>1</sup>
Electrical supply	1/220-240V/50Hz
Electrical consumption (kW)	0,774
Refrigerant	R 404A
Weight (kg)	70

**KM125A (air cooled)**

**KM320MAH-E  
(modular)**



Production capacity (kg/24h)	157
Dimensions W x D x H (mm)	560 x 695 x 770
Electrical supply	1/220-240V/50Hz
Electrical consumption (kW)	0,71
Refrigerant	R 404A
Weight (kg)	69
Corresponding bins	see page 23

**KM320MAH-E (air cooled)**

<sup>1</sup> Legs supplied with KM100A and KM125A, add 90 mm to height (adjustable to max 152 mm).

KM crescent





## KM, crescent ice machines

Modular

### KM515MAH-E



Production capacity (kg/24h)	264
Dimensions W x D x H (mm)	560 x 695 x 770
Electrical supply	1/220-240V/50Hz
Electrical consumption (kW)	1,2
Refrigerant	R404A
Weight (kg)	68
Corresponding bins	see page 23

**KM515MAH-E (air cooled)**

### KM650MAH-E



Production capacity (kg/24h)	333
Dimensions W x D x H (mm)	560 x 695 x 950
Electrical supply	1/220-240V/50Hz
Electrical consumption (kW)	1,2
Refrigerant	R404A
Weight (kg)	77
Corresponding bins	see page 23

**KM650MAH-E (air cooled)**

### KM1301SAH



Production capacity (kg/24h)	584
Dimensions W x D x H (mm)	1219 x 695 x 695
Electrical supply	1/220-240V/50Hz
Electrical consumption (kW)	2,12
Refrigerant	R 404A
Weight (kg)	125
Corresponding bins	see page 23

**KM1301SAH (air cooled)**

**KM1301SRH (for remote condenser) <sup>1</sup>**

**URC12F remote condenser**

**QS Quick remote condenser connection set**

KM1301 can be stacked 2 high for 1168 kg production.

<sup>1</sup> Upon request.

KMI crescent



## KM, crescent ice machines

Modular

### KMD201AA



Production capacity (kg/24h)	190
Dimensions W x D x H (mm)	560 x 625 x 610
Electrical supply	1/220-240V/50/60Hz
Electrical consumption (kW)	0,65
Refrigerant	R 404A/520 g
Weight (kg)	57/73
Bin	Compatible with B-Bins and Lancer dispensers

KMD201AA	(air cooled)
KMD201AWA'	(water cooled)

KMD201 on Lancer dispenser

<sup>1</sup> Upon request.



**HOSHIZAKI**





## FM, flake/nugget ice machines

Hoshizaki FM machines produce flake or nugget ice for a variety of cooling purposes, making them very popular with some of Europe's leading supermarket chains, catering companies, cocktail bars and in the medical and health care sectors. The ice is compressed during production to provide long lasting ice.

FM machines are reliable and feature an evaporator flush in larger models, low maintenance bearings that require no lubrication and durable components throughout.

### Flake ice:

Consists of 70% ice and 30% of water. It is used primarily for cooling purposes. For instance, in the medical sector it is used for cooling down blood and organs or, in the fish industry, to cool, transport and hold fish.

### Nugget ice:

Consists of 80% ice and 20% of water. Nugget ice is more compressed than flake ice and is ideal for display purposes at saladbars or for beverage and fish display.

### Cubelet ice (CM110 only):

Consists of 90% ice and 10% water. It is similar in shape to nugget ice but is harder of its lower water content it is perfect to serve in drinks.

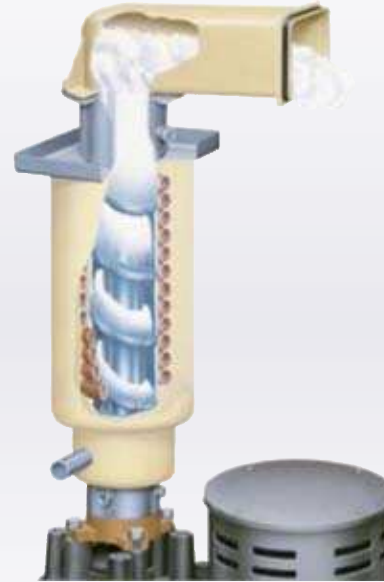

- Ice temperature/type does not “freeze-burn” fish or fresh produce.
- Carbon auger bearing gives longer service life than roller bearing type.
- Quality Stainless steel Auger and Evaporator gives longer service life.
- Machine can be converted to either flake or nugget ice relatively inexpensively.

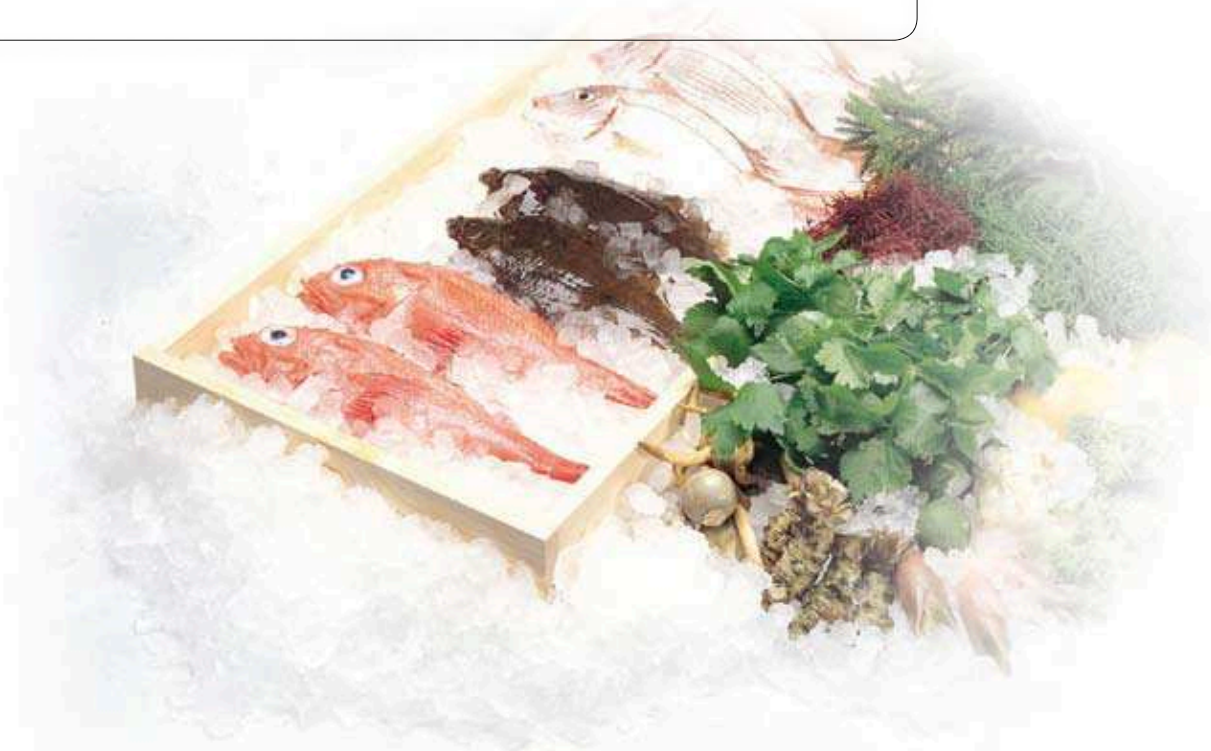

FM flake/nugget



## FM, flake/nugget ice machines

Self contained

### FM8oEE (-N)



Production capacity (kg/24h)	85/65 (N)
Storage bin capacity (kg)	26
Dimensions W x D x H (mm)	640 x 600 x 800
Electrical supply	1/220-240V/50Hz
Electrical consumption (kW)	0,3
Refrigerant	R 134A
Weight (kg)	65

**FM8oEE** (air cooled, flake ice)  
**FM8oEE-N** (air cooled, nugget ice)

### FM12oEE (-N)



Production capacity (kg/24h)	125/110 (N)/110(C)
Storage bin capacity (kg)	26
Dimensions W x D x H (mm)	640 x 600 x 800
Electrical supply	1/220-240V/50Hz
Electrical consumption (kW)	0,52
Refrigerant	R 134A
Weight (kg)	71

**FM12oEE** (air cooled, flake ice)  
**FM12oEE-N** (air cooled, nugget ice)  
**CM110** (air cooled, cubelet ice)

### FM12oEE5o (-N) (double storage bin capacity)



Production capacity (kg/24h)	125/110 (N)
Storage bin capacity (kg)	57
Dimensions W x D x H (mm)	940 x 600 x 800
Electrical supply	1/220-240V/50Hz
Electrical consumption (kW)	0,52
Refrigerant	R 134A
Weight (kg)	81

**FM12oEE5o** (air cooled, flake ice)  
**FM12oEE5o-N** (air cooled, nugget ice)

FM flake/nugget





## FM, flake/nugget ice machines

### Modular

#### FM170AFE (-N)



Production capacity (kg/24h)	170/160 (N)
Dimensions W x D x H (mm)	560 x 700 x 780
Electrical supply	1/220-240V/50Hz
Electrical consumption (kW)	0,62
Refrigerant	R 134A
Weight (kg)	75
Corresponding bins	see page 23

**FM170AFE** (air cooled, flake ice)  
**FM170AFE-N** (air cooled, nugget ice)

#### FM251AFE (-N)



Production capacity (kg/24h)	246/236 (N)
Dimensions W x D x H (mm)	560 x 700 x 780
Electrical supply	1/220-240V/50Hz
Electrical consumption (kW)	0,83
Refrigerant	R 404A
Weight (kg)	86
Corresponding bins	see page 23

**FM251AFE** (air cooled, flake ice)  
**FM251AFE-N** (air cooled, nugget ice)  
**FM251AWFE** (water cooled, flake ice)  
**FM251AWFE-N** (water cooled, nugget ice)

#### FM481AGE (-N)



Production capacity (kg/24h)	500/430 (N)
Dimensions W x D x H (mm)	560 x 700 x 780
Electrical supply	1/220-240V/50Hz
Electrical consumption (kW)	1,522
Refrigerant	R 404A
Weight (kg)	97
Corresponding bins	see page 23

**FM481AGE** (air cooled, flake ice)  
**FM481AGE-N** (air cooled, nugget ice)  
**FM481AWGE** (water cooled, flake ice)<sup>1</sup>  
**FM481AWGE-N** (water cooled, nugget ice)<sup>1</sup>

For remote refrigeration unit:

**FM481ALGE** (flake ice)  
**FM481ALGE-N** (nugget ice)<sup>1</sup>

(1.7 kW at -20°C / 35°C)

<sup>1</sup> Upon request.

FM flake/nugget





## FM, flake/nugget ice machines

Modular

### FM600AHE (-N)



Production capacity (kg/24h)	600/530 (N)
Dimensions W x D x H (mm)	560 x 699 x 780
Electrical supply	1/220-240V/50Hz
Electrical consumption (kW)	1,92
Refrigerant	R 404A
Weight (kg)	110
Corresponding bins	see page 23

- FM600AHE** (air cooled, flake ice)
- FM600AHE-N** (air cooled, nugget ice)
- FM600AWHE** (water cooled, flake ice) <sup>1</sup>
- FM600AWHE-N** (water cooled, nugget ice) <sup>1</sup>

### FM1000ASFE3 (-N)



Production capacity (kg/24h)	1020/850 (N)
Dimensions W x D x H (mm)	765 x 698 x 898
Electrical supply	3/400V/50Hz
Electrical consumption (kW)	3,21
Refrigerant	R 404A
Weight (kg)	153
Corresponding bins	see page 23

For remote condenser:

- FM1000ASFE3** (air cooled, flake ice)
- FM1000ASFE3-N** (air cooled, nugget ice)

- URC2oF:** remote condenser
- OS Quick:** remote condenser connection set

For remote refrigeration unit:

- FM1000ALF** (air cooled, flake ice) <sup>1</sup>
- FM1000ALF-N** (air cooled, nugget ice) <sup>1</sup>

(3.7 kW at -22°C / 35°C)

**We will expand our FM series during the year.  
Please check the website for product updates.**



FM flake/nugget



## FM, flake/nugget ice machines

Hydrocarbon

### The world's first fully CE compliant modular ice maker

Applying available technology and Hoshizaki ice-making expertise, Hoshizaki have produced the world's first fully compliant ice making machine – using only 50% of the legal allowance of Hydrocarbon!

- Hydrocarbon Refrigerant
- CO<sub>2</sub> Blown Foam
- Totally HFC Free – insulation foam and refrigerant do not add to Ozone Depletion or Global Warming
- Low noise
- Long Life
- Fully CE compliant to BS/EN 60335-2-24
- Can be safely and legally installed in any room size

### FMS300AGE-HC hydrocarbon

Available soon!



NEW

Production capacity (kg/24h)	292
Dimensions W x D x H (mm)	388 x 800 x 780
Electrical supply	1/220-240V 50Hz
Electrical consumption (kW)	0,852
Refrigerant	R290 (82g)
Weight (kg)	85 kg
Corresponding bins	see page 23

**FMS300AGE-HC** (air cooled, flake ice)

**FMS300AGE-HC-N** (air cooled, nugget ice)

### FM481AGE-HC



NEW

Production capacity (kg/24h)	450
Dimensions W x D x H (mm)	560 x 720 x 780
Electrical supply	1/220-240V 50Hz
Electrical consumption (kW)	1,665
Refrigerant	R290 (78g + 78 g)
Weight (kg)	105 kg
Corresponding bins	see page 23

**FM481AGE-HC** (air cooled, flake ice)

**FM481AGE-HC-N** (air cooled, nugget ice)

FM flake/nugget





## DSM/DCM/DIM, ice and water dispensers

Hoshizaki's range of ice and/or water dispensers is ideal for any situation where a number of people need access to an ongoing ice/water supply. As well as being compact and energy efficient, the dispensers utilise a very hygienic method of producing, storing and dispensing ice. Simply by pressing a button, ice and/or water is dispensed into your cup or container. This prevents users from touching the ice and minimizes the chance of any bacterial transfer. Also, because during the ice making cycle, ice is dropped directly into the storage hopper, it has no contact with light or air until it is dispensed. Ambient air is prevented from entering the storage hopper by a close fitting lid and a rubber diaphragm on the dispense mechanism, ensuring the hygienic integrity of the ice. Dispensers are therefore ideal for hospital wards, leisure outlets, self service and fast food restaurants, offices and hotel corridors.

- DSM produces shuttle ice.
- DCM produces cubelet ice, ice & water or water.
- DIM produces cube ice (size L).



- **Long service life and durability**
- **Very hygienic – ice dispensed straight into the cup**
- **Water & ice mix at the touch of the button**
- **Convenient for self service areas**
- **Portion control can be set**





## DSM/DCM/DIM, ice and water dispensers

### DSM12CE



Production capacity (kg/24h)	13
Type of ice	Shuttle ice
Storage bin capacity (kg)	3
Dimensions W x D x H (mm)	180 x 510 x 695
Electrical supply	1/220-240V/50Hz
Electrical consumption (kW)	0,26
Refrigerant	R 134A
Weight (kg)	23

#### DSM12CE

### DCM6oFE



Production capacity (kg/24h)	60
Type of ice	Cubelet
Storage bin capacity (kg)	1,9
Dimensions W x D x H (mm)	350 x 480 x 720 (-735)
Electrical supply	1/220-240V/50Hz
Electrical consumption (kW)	0,28
Refrigerant	R 134A
Weight (kg)	45

#### DCM6oFE

### DCM12oFE



Production capacity (kg/24h)	125
Type of ice	Cubelet
Storage bin capacity (kg)	4
Dimensions W x D x H (mm)	350 x 585 x 840 (-855)
Electrical supply	1/220-240V/50Hz
Electrical consumption (kW)	0,604
Refrigerant	R 134A
Weight (kg)	60

#### DCM12oFE

DSM/DCM/DIM



## DSM/DCM/DIM, ice and water dispensers

### DCM230FE



Production capacity (kg/24h)	230
Type of ice	Cubelet
Storage bin capacity (kg)	18
Dimensions W x D x H (mm)	660 x 571 x 1016
Electrical supply	1/220-240V/50Hz
Electrical consumption (kW)	0,815
Refrigerant	R 404A
Weight (kg)	108

### DCM230FE

### DIM30AE



Production capacity (kg/24h)	32
Type of ice	Cube
Storage bin capacity (kg)	15
Dimensions W x D x H (mm)	350 x 500 x 1600
Electrical supply	1/220-240V/50Hz
Electrical consumption (kW)	0,32
Refrigerant	R 134A
Weight (kg)	65

### DIM30AE (L cube)

DSM/DCM/DIM





## B/F, storage bins

In order to ensure ample quantities of ice at all times, Hoshizaki offers a wide range of storage bins that configure perfectly with Hoshizaki ice machines. All storage bins are made of stainless steel and come with legs adjustable between 152-162 mm. The B-bin series is injected with polyurethane foam for outstanding insulation and the interior is finished with Hoshiguard antimicrobial agent.

The size of the bins depends on several factors: the capacity of the machine, the average daily demand and the peak demand.

Sometimes a top kit is necessary to close off the bin completely. Please check table below for the configurations possible with the appropriate top kit.



	FM170/251 FM481/600 KM320 KM515 KM650 KMD201 IM240A	FMS300	2xFMS300 FM1000	2xFM170/251 2xFM481/600 2xKM320 2xKM515 2xKM650 2xIM240A	2xKM201D	KM1301	IM240DME
B301	No top kit	Available					
B501	Top kit 8D	Available	No top kit				
B801	Top kit 8D+18D	Available	Top kit 18D	Top kit 4DM	TK4DM+4DR	No top kit	Top kit IMD
F650-44S						Top kit incl.	Top kit incl.
F950-48S						Top kit incl.	Top kit incl.
F1025-52S						Top kit incl.	Top kit incl.

B/F bins



## B/F, storage bins



**B301SA**



**B501SA**



**B801SA**

	Bin capacity (kg)	Dimensions W x D x H (mm) (incl. legs)	Weight (kg)	Price
<b>B301SA</b>	144	559 x 820 x 1016	37 (Net) / 49 (Gross)	
<b>B501SA</b>	217	762 x 820 x 1016	47 (Net) / 62 (Gross)	
<b>B801SA</b>	348	1219 x 820 x 1016	64 (Net) / 86 (Gross)	

Bin dividers on request.

Top kits:

**Top kit 4 DM**

**Top kit 4 DR**

**Top kit 8 D**

**Top kit 18 D**

**Top kit IMD**

	Bin capacity (kg)	Dimensions W x D x H (mm) (incl. legs)	Weight (kg)	Price
<b>F650-44S</b>	299	1118 x 800 x 1016	81	
<b>F950-48S</b>	431	1220 x 800 x 1270	94	
<b>F1025-52S</b>	467	1321 x 800 x 1270	93	

Other bins and/or bin dividers on request.

B/F bins





## Transport systems

### SBF



Frame dimensions W x D x H (mm)	720 x 960 x 990
Cart W x D x H (mm)	560 x 1090 x 890
Cart positioned in frame W x D x H (mm)	720 x 1150 x 990

The cart require 1100mm space to allow removal from the frame.

#### Frame and cart

#### Extra cart

### ITS



	No. of carts	Bin capacity (kg)	Dimensions W x D x H (mm)	Weight (kg)	Price
ITS100 <sup>1</sup>	1	46 (+109)	788 x 1016 x 1178	82	
ITS500-31	1	227 (+109)	788 x 1016 x 1524	203	
ITS600-31 <sup>1</sup>	1	272 (+109)	788 x 1016 x 1702	171	
ITS700-31	1	318 (+109)	788 x 1220 x 1905	212	
ITS1350-60 <sup>1</sup>	2	612 (+218)	1524 x 1220 x 1905	386	
ITS2250-60 <sup>1</sup>	2	955 (+218)	1524 x 1220 x 2464	441	

Optional:

#### Additional ice cart

#### Set of 6 totes

Also available upon request:

- Full range of stands for ice machines and storage bins.
- Ice machines with full stainless steel frames and mobile cart.
- Other storage, transport, bagging and dispensing systems.

<sup>1</sup> Upon request.



**HOSHIZAKI**



## C, crushers

These ice crushers are easy to operate and very compact. They are ideal for crushing small quantities of ice cubes for perfectly presented drinks. Crushers are small enough to place on bars or countertops and will crush 3-5 kg of ice in just 60 seconds.

**C103**



Crush capacity (kg/min)	3
Storage capacity (kg)	1
Dimensions W x D x H (mm)	180 x 330 x 320
Electrical supply	1/220-240V/50Hz
Electrical consumption (kW)	0,15
Weight (kg)	10

**C103**

**C105**



Crush capacity (kg/min)	5
Storage capacity (kg)	5
Dimensions W x D x H (mm)	370 x 310 x 510
Electrical supply	1/220-240V/50Hz
Electrical consumption (kW)	0,15
Weight (kg)	25

**C105**



## HRE/HFE, refrigerators and freezers

### Uprights

Hoshizaki's upright refrigerators and freezers can easily be adjusted on site over a wide temperature range providing a high degree of versatility. The durable units are constructed internally and externally from high grade stainless steel, have integrated electronic controls, lockable, self closing doors and heavy duty castors. All uprights have automatic defrost and are supplied with 4 heavy duty shelves. The upright range comprises single and double door refrigerators and freezers with 631 and 1379 litre capacities respectively.

- Energy efficient DC fan (80% more energy efficient than AC fan)
- Easy cleaning because of round edges
- Heated front frame and efficient insulation – no outside condensation on panels
- Evaporator Defrost Cycle every 6 hours maintains energy efficiency
- Doors auto close less than 90 degrees.

**HRE70B**



Net capacity (L)	631
Temperature (°C)	0 to 16
Dimensions W x D x H (mm)	700 x 850 x 2017
Electrical supply	1/220-240V/50Hz
Electrical consumption (kW)	0,355
Refrigerant	R134A
Weight (kg)	116

**HRE70B**

**HRE70B-2**

**HRE70B-2**

**HFE70B**



Net capacity (L)	631
Temperature (°C)	-25 to -7
Dimensions W x D x H (mm)	700 x 850 x 2017
Electrical supply	1/220-240V/50Hz
Electrical consumption (kW)	0,513
Refrigerant	R404A
Weight (kg)	116

**HFE70B**

**HFE70B-2**

**HFE70B-2**

HRE/HFE uprights





## HRE/HFE, refrigerators and freezers

### Uprights

**HRE140B**



**HRE140B-2**

Net capacity (L)	1379
Temperature (°C)	0 to 16
Dimensions W x D x H (mm)	1400 x 850 x 2017
Electrical supply	1/220-240V/50Hz
Electrical consumption (kW)	0,585
Refrigerant	R134A
Weight (kg)	164

**HRE140B**

**HRE140B-2**

**HFE140B**



**HFE140B-2**

Net capacity (L)	1372
Temperature (°C)	-25 to -7
Dimensions W x D x H (mm)	1400 x 850 x 2017
Electrical supply	1/220-240V/50Hz
Electrical consumption (kW)	0,747
Refrigerant	R404A
Weight (kg)	174

**HFE140B**

**HFE140B-2**

Optional:

**Additional shelf (2/1 gastronorm)**

**Supportrail**

**Adjustable leg**



HRE/HFE uprights



## RTE/FTE, refrigerators and freezers

### Counters

The counter refrigerators and freezers are constructed from high grade stainless steel featuring 304 grade interiors, promising long term durability and efficiency. Because temperatures are adjustable between +12°C and -6°C on the refrigerators and -7°C and -25°C on the freezers, a single unit can be used for different types of storage as requirements change or seasonal changes dictate menu variations. The refrigerators and freezers are efficient on maintenance and energy usage as they all feature a front loaded, cleanable air filter, a concept pioneered by Hoshizaki.

- **Stainless worktop can be used to prepare food**
- **Available in variety of doors or drawers (or combination of both)**
- **Compressor assembly can be easily removed for service**
- **Energy efficient DC fan**
- **Wheels (castors) for easy moving to clean floor underneath and behind**

#### RTE12oSDB-P

**Available soon!**



Net capacity (L)	272
Temperature (°C)	-6 to 12
Dimensions W x D x H (mm)	1200 x 700 x 850
Electrical supply	1/220-240V/50Hz
Refrigerant	R134A
Weight (kg)	90

#### RTE125SFA (2 doors)<sup>1</sup>

#### FTE12oSDB-P

**Available soon!**



Net capacity (L)	272
Temperature (°C)	-27 to -7
Dimensions W x D x H (mm)	1200 x 700 x 850
Electrical supply	1/220-240V/50Hz
Refrigerant	R404A
Weight (kg)	95

#### FTE125SFA (2 doors)

<sup>1</sup> Drawers are available upon special request.

RTE/FTE counters





## RTE/FTE, refrigerators and freezers

### Counters

#### RTE17oSDB-P

**Available soon!**



Net capacity (L)	424
Temperature (°C)	-6 to 12
Dimensions W x D x H (mm)	1660 x 700 x 850
Electrical supply	1/220-240V/50Hz
Refrigerant	R134A
Weight (kg)	115

#### RTE17oSDB-P (3 doors)<sup>1</sup>

#### FTE17oSDB-P

**Available soon!**



Net capacity (L)	424
Temperature (°C)	-27 to -7
Dimensions W x D x H (mm)	1660 x 700 x 850
Electrical supply	1/220-240V/50Hz
Refrigerant	R404A
Weight (kg)	120

#### FTE17oSDB-P (3 doors)

Optional:

**Additional shelf (1/1 gastronorm)**

**Shelf slide**

**Castor**

**Leg**

**Splash back top (for RTE/FTE125)<sup>2</sup>**

**Splash back top (for RTE/FTE170)<sup>2</sup>**

<sup>1</sup> Drawers are available upon special request.

<sup>2</sup> Splash back tops upon special request (adding 100 mm to height).







## HNC, sushi cases

With rounded glass windows and black exterior Hoshizaki sushi cases provide an eye catching point of sales display to attract customers. The HNC range has a unique evaporator system to ensure maximum cooling performance creating a stable temperature and humidity level to ensure perfect presentation. Food is easily accessible through sliding doors located on the operator's side, which can be removed for cleaning the inside of the unit. Supplied food plates can be turned upside down to improve cooling performance. There are two versions available with the compressor unit sited either on the left or right side.

*Please note: This machine is not intended to be used as a storage cabinet but only for food display and has to be defrosted/cleaned daily.*

- **Attractive counter top display**
- **Easy clean design**
- **Stable humidity and temperature for longer lasting food quality (no forced air circulation to dry-out food)**
- **Does not defrost and drop condensation onto the displayed food.**

### HNC120AE-L/R



(Compressor right side)

Net capacity (L)	42
Temperature (°C)	4
Dimensions W x D x H (mm)	1200 x 345 x 270
Electrical supply	1/220-240V/50Hz
Electrical consumption (kW)	0,15
Refrigerant	R134A
Weight (kg)	32
<b>HNC120AE-L (compressor left side)</b>	
<b>HNC120AE-R (compressor right side)</b>	

### HNC150AE-L/R



(Compressor left side)

Net capacity (L)	57
Temperature (°C)	4
Dimensions W x D x H (mm)	1500 x 345 x 270
Electrical supply	1/220-240V/50Hz
Electrical consumption (kW)	0,15
Refrigerant	R134A
Weight (kg)	37
<b>HNC150AE-L (compressor left side)</b>	
<b>HNC150AE-R (compressor right side)</b>	

HNC cases





## HNC, sushi cases



(Compressor right side)

### HNC180AE-L/R

Net capacity (L)	72
Temperature (°C)	4
Dimensions W x D x H (mm)	1800 x 345 x 270
Electrical supply	1/220-240V/50Hz
Electrical consumption (kW)	0,15
Refrigerant	R134A
Weight (kg)	42

**HNC180AE-L** (compressor left side)

**HNC180AE-R** (compressor right side)



(Compressor left side)

### HNC210AE-L/R

Net capacity (L)	87
Temperature (°C)	4
Dimensions W x D x H (mm)	2100 x 345 x 270
Electrical supply	1/220-240V/50Hz
Electrical consumption (kW)	0,15
Refrigerant	R134A
Weight (kg)	47

**HNC210AE-L** (compressor left side)

**HNC210AE-R** (compressor right side)

HNC cases





# ROX

## E-water, a revolutionary cleaning aid

**Hoshizaki's ROX can turn simple tap water into an effective means of cleaning. It has antibacterial qualities and can compare with the best detergents.**

### The chemical process of creating E- water

ROX uses electrolysis via a cathode and anode to turn tap water into Alkaline and Acidic water. Salt is an essential ingredient in the process and this is provided by the salt water tank. In addition a water softener is required in the water supply to the machine to ensure best quality water. The basic principle is that at the Anode, chlorine gas reacts with the water to produce Hypochlorous acid. As a result the water from the anode has a pH of 3.0 or less (acidic water) with available chlorine of 20-60mg. The Hypochlorous acid (HClO) is up to 80 times more effective than chemicals and the chlorine generated is non residual, so will not remain on foods etc. At the cathode, water decomposes and becomes hydrogen and hydroxyl ions. Sodium hydroxide is generated with a pH typically of 11.0 (alkaline water) and of course sodium hydroxide is found in soap products.

### Cleaning and sanitising

Alkaline and acidic water have two main functions within the cleaning process. Alkaline water dissolves proteins and oil. Acidic water is effective in sanitizing and bacteria control. So for example, by first washing a cutting board with alkaline water removes any oil or grease and then followed by acidic water sanitizes the cutting board. Remember acidic water is up to 80 times more effective compared to a chemical. In the food service industry, the applications for E-water and consequential reduction of chemical use with benefits to the environment are too long to list here. Typical applications of cleaning and sanitizing are common to every establishment from floors, work surfaces, cooking utensils, hands, fryers, toilets, machinery, refrigerators and of course food itself. Using ROX can even help to prevent food poisoning! When the work surface, utensils and the food itself is washed with E-water there is a reduced chance for bacteria to survive. Since it does not leave any residue behind it will not affect the quality or taste of the food in any case. By using either alkaline and then acidic water or either separately, almost every cleaning and sanitization application can be completed safely and chemical free.

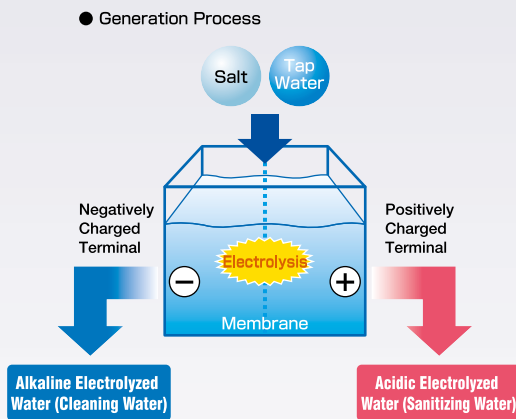

- No need for chemicals (save costs).
- More effective than the average chemical.
- No residue is left behind.
- Not harmful for the human body.
- Environmental friendly.
- One year warranty.



ROX e-water





## ROX

### ROX-10WB-E



The ROX-10WB-E unit requires little space and can be mounted on the wall above the sink. The water softener and the salt tank can be placed underneath the sink.

Production capacity (L/min.)	0,7 - 1,5
Ambient temperature range (°C)	5 - 35
Water temperature range (°C)	5 - 30
Dimensions W x D x H (mm)	350 x 185 x 430
Exterior	Polyester painted galvanized steel, ABS plastic
Electrical supply	1/100-240V/50/60Hz
Electrical consumption (kW)	0,2
Electrolysis system	Membrane electrolysis
Weight (kg)	13 (Net)/ 16 (Gross)
Water treatment	Softener required other treatment required depending on water quality
Electrolyte	Salt which contains a minimum of 99% Sodium Chloride
Production quality	Acidic Water: Approx. pH 2.3 - 3.3 Available chlorine: 20 ppm or more Alkaline Water: Approx. pH 11.0 or more
Water supply	Tap water with a water pressure of 1.5 - 7.5 BAR

### ROX-10WB-E

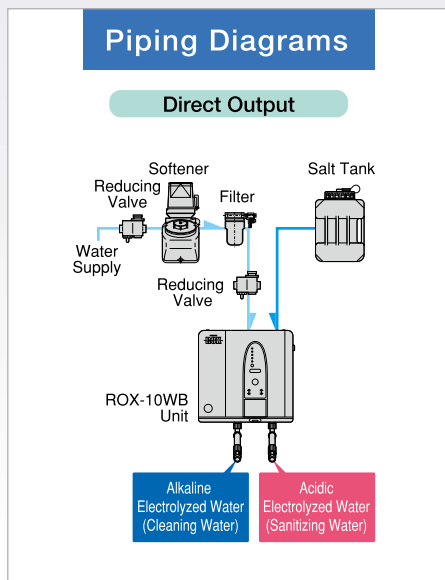

Replace alkaline (cleaning water) and acidic (sanitizing water) electrolyzed water nozzles in accordance with duration of operation.

ROX e-water





## ROX

The remote controller of the ROX-20TB-E unit can be mounted on the wall above the sink, the rest of the unit can be placed underneath the sink.

### ROX-20TB-E



Production capacity (L/min.)	1,5 - 3,0
Ambient temperature range (°C)	5 - 35
Water temperature range (°C)	5 - 30
Dimensions W x D x H (mm)	280 x 400 x 310
Exterior	Polyester painted stainless and galvanized steel, ABS plastic
Electrical supply	1/100-240V/50/60Hz
Electrical consumption (IWh)	0,34
Electrolysis system	Membrane electrolysis
Weight (kg)	15 (Net)/ 28 (Gross)
Water treatment	Softener required other treatment required depending on water quality
Electrolyte	Salt which contains a minimum of 99% Sodium Chloride
Production quality	Acidic Water:     Approx. pH 2.3 - 3.3 Available chlorine: 20 ppm or more Alkaline Water:    Approx. pH 11.0 or more
Water supply	Tap water with a water pressure of 1.5 - 7.5 BAR

### ROX-20TB-E

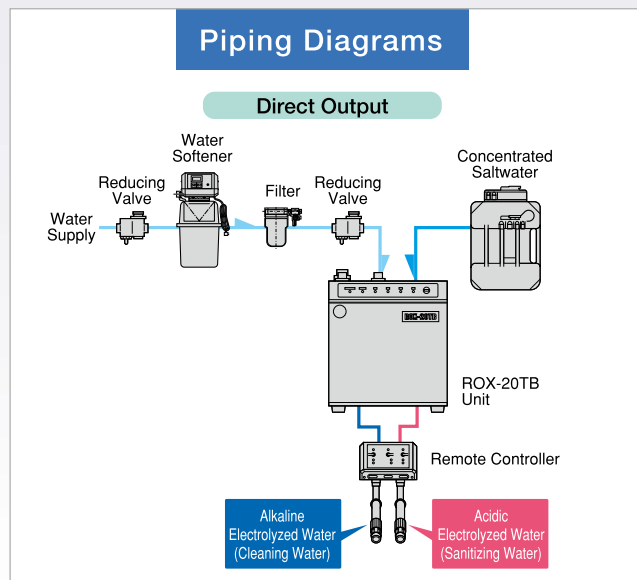

Replace alkaline (cleaning water) and acidic (sanitizing water) electrolyzed water nozzles in accordance with duration of operation.

ROX e-water





## ROX

### ROX-30SA



NEW

Production capacity (L/min.)	1,5 - 3,0
Ambient temperature range (°C)	5 - 35
Water temperature range (°C)	5 - 30
Dimensions W x D x H (mm)	1400 x 660 x 1800
Exterior	Polyester painted galvanized steel, ABS plastic
Electrical supply	1/100-240V/50/60Hz
Electrical consumption (kW)	Normal 0,27
Pump operation (kW)	0,62/0,67
Electrolysis system	Membrane electrolysis
Weight (kg)	230 (Net) / 280 (Gross)
Water treatment	Softener included in ROX other treatment depending on water quality
Electrolyte	Salt which contains a minimum of 99% Sodium Chloride
Production quality	Acidic Water: Approx. pH 2.9 - 3.3 Available chlorine: 20 ppm or more Alkaline Water: Approx. pH 10.5 - 11.0
Water supply	Tap water with a water pressure of 1.5 - 7.5 BAR

### ROX-30SA

### ROX-60SA



NEW

Production capacity (L/min.)	3,0 - 6,0
Ambient temperature range (°C)	5 - 35
Water temperature range (°C)	5 - 30
Dimensions W x D x H (mm)	1400 x 660 x 1800
Exterior	Polyester painted galvanized steel, ABS plastic
Electrical supply	1/100-240V/50/60Hz
Electrical consumption (kW)	Normal 0,45
Pump operation (kW)	0,8/0,85
Electrolysis system	Membrane electrolysis
Weight (kg)	250 (Net) / 300 (Gross)
Water treatment	Softener included in ROX other treatment depending on water quality
Electrolyte	Salt which contains a minimum of 99% Sodium Chloride
Production quality	Acidic Water: Approx. pH 2.9 - 3.3 Available chlorine: 20 ppm or more Alkaline Water: Approx. pH 10.5 - 11.0
Water supply	Tap water with a water pressure of 1.5 - 7.5 BAR

### ROX-60SA





## Accessories

### Additional tank for ROX30/60



Additional tank for ROX30/60

### Remote indicator for ROX30/60

Remote indicator for ROX30/60

### Auto outlet valve (including LED lighting for ROX30/60)

Auto outlet valve (including LED lighting for ROX30/60)



Sometimes it is necessary to use a water filter for your ice maker or ROX. Water filters remove many particles and chemicals found in tap water. They will reduce cleaning frequency, allow top performance, and improve the quality of your ice. Also, lime and mineral build up will be greatly reduced inside your ice maker if you use a filter. Ensure that the filter is changed regularly according to directions. Please contact our sales office for more information about water filters or other accessories.

